

Model 9000

**Series 9000 Control Valves
RESEARCH® Control Valves**

Technical Brief



- *3 Sizes: 1", 1-1/2" and 2"*
- *ASME B16.34, CL300*
- *NPT/Flangeless Ends - Std*
 - *Optional Flanged Ends*
- *Standard 316SST Construction*
 - *Field Reversible Actuator*
 - *Adjustable Spring Loading*
- *Liquid • Gas • Steam*
- *Chemical • Petroleum*
- *Textiles • Pulp/Paper*
- *Pharmaceutical • HVAC*
 - *Food and Beverage*
- *Automotive • Tires • Rubber*



DESCRIPTION

The Model 9000 is an ANSI Class 300 globe style valve with bolted bonnet and post guided innervolve. It is available in 1", 1-1/2" and 2" pipe size. The body, bonnet and innervolve are standard in 316SST or optional Alloy C. The standard body, configured in the Flangeless/NPT version, can be installed using NPT fittings or clamped between matching companion flanges. Each size valve is also available with conventional flanges in either the same nominal size as the valve body or oversized flanges can be adapted to smaller bodies.

Each valve is available with several innervolve sizes, the largest having an integral seat for maximum Cv. Reduced Cv innervolves fit a threaded body with replaceable seat rings. The unique packing/bonnet design provides high performance and quick easy maintenance when necessary. The Model 9000 is also available with extended bonnets for hot or cold service. Optional double packing, in either PTFE or REK®, for fugitive emission control.

The high performance Model 9050 actuator, a multi-spring & diaphragm design, is field reversible from Air-To-Open to Air-to-Close without additional parts. The yoke and actuator housings are made of carbon steel and coated with epoxy for corrosion resistance.

Standard material for external hardware is 300 series stainless steel. The 3-15 psi spring set is adjustable to 8-20 psi and the 6-30 psi spring set is adjustable to 16-40 psi to allow the user a wide range of shut-off capability.

APPLICATIONS

The Model 9000 is designed for modulating control of liquids and vapors in medium duty industrial applications where performance, quality and small physical size are important. The rugged design offers features and performance levels normally found in more expensive, larger valves.

The unit is designed to handle fluids and environments found in chemical plants, pulp & paper and textile mills, refineries and many other demanding industries.

MATERIALS OF CONSTRUCTION

Body: 316SST [CF8M ASTM A351]
Bonnet: 316SST [ASTM A479]
Bonnet Flange: 316SST [CF8M]
Bolting: Gr 5 with Xylan® coating
Gasket: Grafoil® Gr GTA
Innervolve: 316SST [ASTM A479]
Packing: PTFE chevron ring

Material Options
Body: Alloy C [CW-2M ASTM A494]
Bonnet: Alloy C276 barstock
Innervolve: Alloy C276, Stellite 316, 316 w/ Teflon PFA soft seat
Packing: Grafoil®, Kalrez® [REK®]
Bolting: Strain Hardened 316SST

ACTUATOR

The Model 9050 actuator is available in either Air-To-Open/Spring-to-Close or Air-To-Close/Spring-to-Open and is field reversible. It comes with either 3 springs for a 3-15 psi signal range or 6 springs for a 6-30 psi signal range. Both ranges are adjustable to match bench loading with the requirements of the application.

MATERIALS OF CONSTRUCTION

Pressure cases: Steel/Epoxy
Yoke: Steel/Epoxy
Diaphragm: Nitrile/Polyester
Springs: 17-7PH SST
Diaphragm Plate/Piston: High Strength Aluminum with Hard Anodized coating.
Hardware: 300 SST
Options
Electroless Nickel coating on pressure cases and yoke.

STANDARD FEATURES

- Designed to ANSI and ISA standards
- Dual body mounting [NPT/Flangeless]
- Wide range of innervolves
- Linear, Equal Percent or On-Off
- ANSI Class IV seat leak standard
- Encapsulated body gasket
- MoS2 filled nylon stem bushings
- No brass or asbestos
- Epoxy coated steel parts
- Adjustable spring loading
- Replaceable seats [Reduced Cv innervolves only]

OPTIONS

- Stellite® Innervolve
- Teflon® PFA soft seating
- Class V or VI seat test
- Graphite packing
- Extended bonnets [to 18"] for hot or cryogenic service.
- Double stuffing box

DESIGN STANDARDS

- Structural: ASMEI B16.34-1996
- Bolting: ASME Section VIII, Appendix 2 and ASME B16.34
- Seat leakage: ANSI/FCI 70-2-1991
- Cv: ISA- 75.01, 75.02, and 75.11
- Face to Face [Std]: ISA S75.04
- Face to Face [Flanged]: ASME B16.10-1992 [Optional F/F dimensions available]
- Flange finish: ASME B16.5-1996 [standard is concentric serrations]
- Materials: ASTM designations
- Code Welding: ASME Section VIII
- Accessory mount: IEC 534 [yoke]

ACCESSORIES

- Positioner
- i/P positioner
- i/P transducer
- Gauges
- Filter-Regulator
- Solenoid
- Limit Switches [1 or 2]
- Position transmitter

SPECIAL DESIGNS

If you have a special requirement, both Series 9000 and RESEARCH® Control valves are available in a wide variety of configurations. If the literature does not contain a configuration that suits your application, we specialize in custom and special valve designs. Contact your local representative or our factory for assistance.

For high quality control in non-corrosive applications, ask about the model 9100 bronze valve with SST innervolve, in 1/2" to 2" NPT.

Badger® is a registered trademark of Badger Meter, Inc.
GRAFOIL® is a registered trademark of Graftech Inc.
Hastelloy® is a registered trademark of The Haynes Stellite Company.
Kalrez® is a registered trademark of DuPont Dow Elastomers.
Krytox® is a registered trademark of E.I. du Pont de Nemours and Company.
Monel® is a registered trademark of Inco Alloys International, Inc.
Nylatron® is a registered trademark of The Polymer Corporation.
REK® is a registered trademark of Badger Meter, Inc.
RESEARCH® is a registered trademark of Badger Meter, Inc.
Stellite® is a registered trademark of Haynes Stellite Company.
Teflon® is a registered trademark of E.I. du Pont de Nemours and Company.
Xylan® is a registered trademark of Whitford Corporation.
Zymaxx® is a registered trademark of E.I. du Pont de Nemours and Company.

Typical
1" body-bonnet
assembly with
Integral seat.

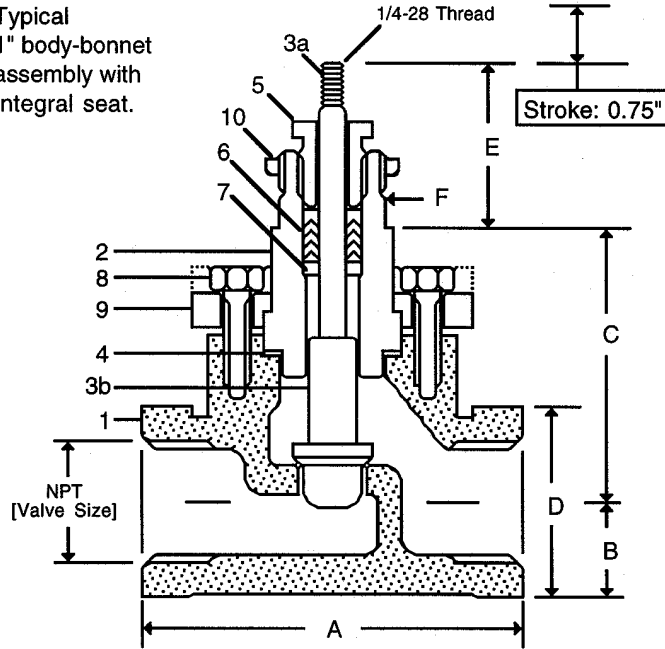

BODY ASSEMBLY DIMENSIONS
[For complete valve dimensions, see back page.]

1" Valve Size [DN 25]		1.5" Valve Size [DN 40]		2" Valve Size [DN 50]	
Inches mm		Inches mm		Inches mm	
A	4.0" 102	A	4.5" 115	A	4.875" 124
B	1.0" 25.4	B	1.5" 38.1	B	1.75" 44.5
C	3.2" 81.3	C	3.46" 87.9	C	3.59" 91.2
D	2.0" 50.8	D	2.88" 73.1	D	3.625" 92.1
E	1.68" 42.7	E	1.68" 42.7	E	1.68" 42.7
F	1.125" 28.6	F	1.125" 28.6	F	1.125" 28.6

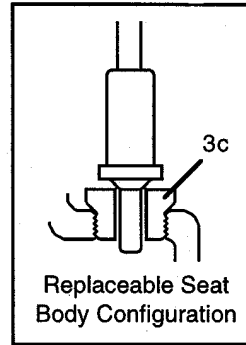

APPROXIMATE VALVE WEIGHT
[NPT Body with Size 35 Actuator]

	Lbs.	Kgs.
1"	28	12.8
1-1/2"	31	14.1
2"	34	15.5

Stroke [All Sizes of M9000]: 0.75"

PARTS AND MATERIAL LIST [Unless noted, standard material is 316 SST]

ITEM NO.	DESCRIPTION	PART NUMBERS		
		1" Valve	1.5" Valve	2" Valve
1a	Body [for replaceable seat]	525966-0001	526149-0001	526151-0001
1b	Body [with integral seat]	525956-0001	526148-0001	526150-0001
2	Bonnet [standard length]	525949-0001	526152-0001	525952-0001
3a	Stem, innervalue	Innervalue part numbers vary with Cv and material. Consult the factory for complete innervalue set part numbers.		
3b	Innervalue & guide			
3c	Seat [if applicable]			
4	Gasket [Grafoil®]	512711-0001	512702-0001	512726-0001
5	Packing Gland	525950-0001	525950-0001	525950-0001
6	Packing Kit [PTFE]	543242-0001	543242-0001	543242-0001
7	Packing Adapter	525951-0001	525951-0001	525951-0001
8	Hex Screws [Gr 5 Steel]	526119-0001	526119-0003	526119-0004
9	Bonnet Flange	512681-0001	512723-0001	512722-0001
10	Yoke Locknut	525944-0001	525944-0001	525944-0001

PRESS vs TEMPERATURE RATING

PSIG	Temperature		BARG	NOTES
	deg. F	deg C		
720	100	38	49.6	<ul style="list-style-type: none"> Below -20F and above +500F, use optional SST bonnet studs. Consult factory for cryogenic service. Max. temp for TFE packing is 450F. Consider extended bonnets or Grafoil packing above 450F. Consult factory for limits on TFE soft seat. Consider Stellite for +600F service.
620	200	93	42.7	
560	300	149	38.6	
515	400	204	35.5	
480	500	260	33.1	
450	600	316	31.0	
430	700	371	29.6	
415	800	427	28.6	
395	900	482	27.2	
365	1000	538	25.1	

Above information taken from ANSI Class 300 pressure vs. temperature data for CF8M 316SST. For information or part numbers on other materials, consult the factory.

Detailed actuator and valve assembly drawings are available on request from the factory.

Innervalue Information

NOTE: The largest Cv in each valve size has an integral seat. All other Cv's have replaceable seats.

Valve Size	Orifice Dia.[in.]	Orif.area sq.inches	F _L	Seat Config.	Cv [Linear]	Cv [Percent]	Max. Oper. Δ P [psi]	Max. Δ P Shut-off
2"	1.500	1.77	.85	Integr.	25	20	150	300*
2"	1.125	1.00	.86	Repl.	21	17	275	550*
2"	0.812	0.52	.88	Repl.	15	14	540	720*
2"	0.625	0.31	.90	Repl.	7	6.5	660	720
1.5"	1.250	1.23	.85	Integr.	15.5	13	225	450*
1.5"	0.812	0.52	.87	Repl.	11	10	540	720*
1.5"	0.625	0.31	.90	Repl.	7	6.5	660	720
1.5"	0.625	0.31	.92	Repl.	4	4	660	720
1"	0.812	0.52	.85	Integr.	8.3	7.0	540	720*
1"	0.500	0.20	.87	Repl.	5.3	4.5	660	720
1"	0.500	0.20	.89	Repl.	2	2	660	720
1"	0.500	0.20	.91	Repl.	1	1	660	720
1"	0.156	0.02	.93	Repl.	0.5	0.5	720	720
1"	0.156	0.02	.94	Repl.	0.2	0.2	720	720
1"	0.156	0.02	.95	Repl.	0.1	0.1	720	720
1"	0.156	0.02	.96	Repl.	0.05	0.05	720	720
1"	0.156	0.02	.97	Repl.	0.02	N/A	720	720

Typical Innervalue Rangeability

- Linear: 50:1
- Equal Percent: 60:1

Notes:

- Pressure drop limits for soft seated trims are 50% of those listed.
- Body recovery coefficient [FsubL] per ISA 75.02-1988 at maximum innervalue opening.
- Shut-off pressures marked with an asterisk [*] require six [6] actuator springs to obtain required preload.
- Pressures listed under Max. oper. DeltaP or Max. shut-off DeltaP relate to actuator preload requirements and innervalue guide limits. Since fluid and application criteria have a bearing on innervalue performance, some applications may require hardened trim and/or extra preload. In certain applications, the pressures listed may wear or erode the innervalue material.

OUTLINE DIMENSIONS FOR COMMON MODEL 9000 VALVES

- Face-to-face and bonnet lengths listed are considered standard.
- Flanged valves are available in custom Face-to-face lengths.
- Some valves are available with over or under sized flanges.
- Air Connection - Standard: 1/4" NPT Optional: G1/4 BSP-P

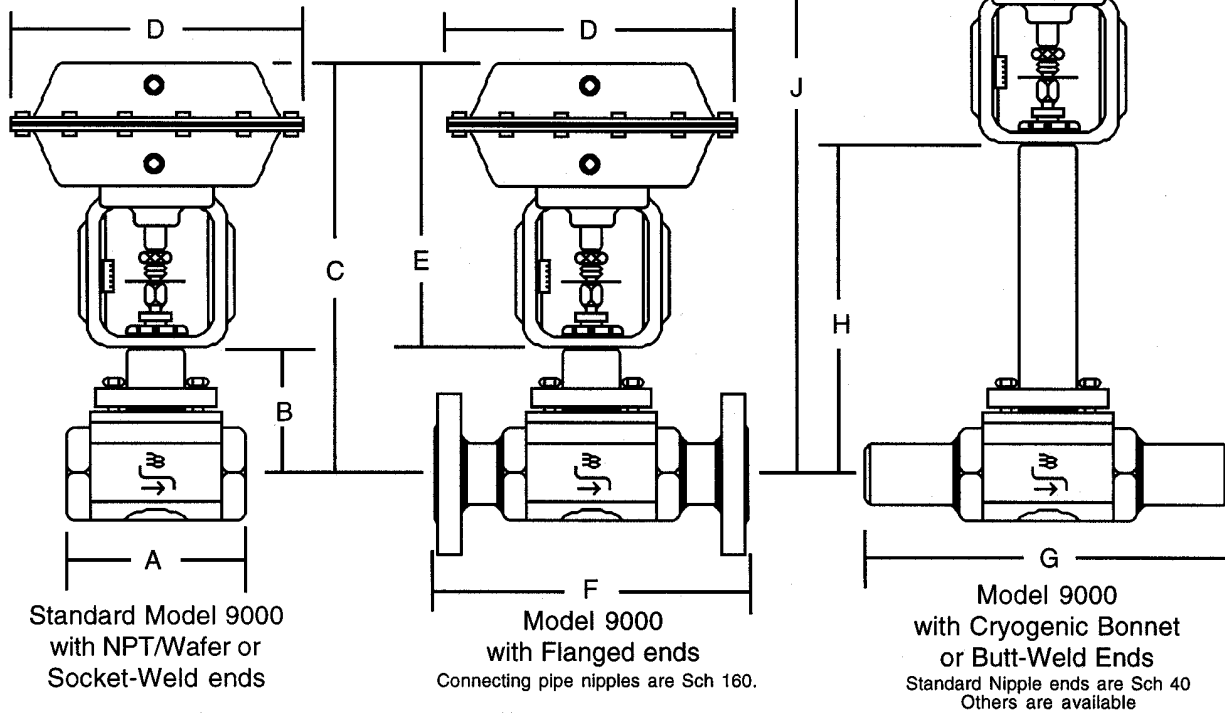

DESCRIPTION	DIMENSIONS		
	1" Valve DN 25 in. [mm]	1-1/2" Valve DN 40 in. [mm]	2" Valve DN 50 in. [mm]
A Standard body length [incl. Flangeless/NPT and Socket Wld]	4.00" [102]	4.50" [115]	4.875" [124]
B1 Centerline of body to yoke mounting point [standard bonnet]	3.20" [81]	3.46" [88]	3.59" [91]
B2 Centerline of body to yoke mounting point [1" ext.or Dbl Pack.]	4.20" [107]	4.46" [114]	4.59" [117]
C1 Centerline of body to top of actuator [standard bonnet]	13.68" [348]	13.94" [348]	14.07" [358]
C2 Centerline of body to top of actuator [1" ext. or Dbl Pack.]	14.68" [373]	14.96" [380]	15.07" [383]
D Size 35 actuator Diameter	9.81" [250]	9.81" [250]	9.81" [250]
E Size 35 actuator Height	10.48" [267]	10.48" [267]	10.48" [267]
F1 Flanged body length [with ANSI CL 150 Flanges]	7.25" [184]	8.75" [222]	10.00" [254]
F2 Flanged body length [with ANSI CL 300 Flanges]	7.75" [197]	9.25" [235]	10.50" [267]
G Butt-Weld body length [any pipe schedule. per ISA75.15-1993Long Pattern]	8.25" [210]	9.88" [251]	11.25" [286]
H1 Centerline of body to yoke mounting point [10" Cryo bonnet]	10.00" [254]	10.00" [254]	10.00" [254]
H2 Centerline of body to yoke mounting point [14" Cryo bonnet]	14.00" [356]	14.00" [356]	14.00" [356]
H3 Centerline of body to yoke mounting point [18" Cryo bonnet]	18.00" [457]	18.00" [457]	18.00" [457]
J1 Centerline of body to top of actuator [10" Cryo bonnet]	20.50" [521]	20.50" [521]	20.50" [521]
J2 Centerline of body to top of actuator [14" Cryo bonnet]	24.50" [622]	24.50" [622]	24.50" [622]
J3 Centerline of body to top of actuator [18" Cryo bonnet]	28.50" [724]	28.50" [724]	28.50" [724]

Dimensions subject to change. Detailed engineering drawings of valves and actuators are available from the factory on request.



Please see our website at
www.badgermeter.com
for specific regions and contacts.

Due to continuous research, product improvements and enhancements, Badger Meter reserves the right to change product or system specifications without notice, except to the extent an outstanding bid obligation exists.



BadgerMeter, Inc.

6116 E. 15th Street, Tulsa, Oklahoma 74112
(918) 836-8411 / Fax: (918) 832-9962

www.badgermeter.com