

DESCRIPTION

The EVA-100 & EVA-200 are multi-featured actuators with the capability to accept analog control signals. The design provides smooth, highly accurate positioning, with positive position-lock when not in motion. These rugged actuators will withstand the most adverse environmental conditions. The EVA-100 & EVA-200 were developed specifically to fit all RESEARCH CONTROL Valves including the larger Model 9000 & 9100. Their accurate positioning and high thrust makes them well suited for all research and process applications.

The unit features:

- Microprocessor-controlled, linear stepper motor
- 4-20 mA, 0-5 VDC, 0-10 VDC analog inputs
- Position 4-20 mA analog output
- Incremental Control Input (On/Off control)
- Choice of 100 pound or 200 pound thrust units
- Accurate and repeatable positioning
- Adjustable split range
- Quick and simple zero and span input and output adjustments
- Adjustable stroke up to 1"
- User selectable direct or reverse action
- Controlled seating force to prevent innervalve damage
- Rugged epoxy coated aluminum housing
- 115VAC, 230VAC operation

OPERATION

The Model EVA-100/200 consists of a microprocessor-controlled, stepper motor. The stepper motor produces torque, which is transmitted to the output shaft through a non-rotating drive screw. This allows the low torque, high speed motor output to be converted to high thrust for actuator output shaft motion. The built-in servo drive amplifier controls the stepper motor's speed and direction. It also controls actuator end limits, motor torque, deadband and 4-20 mA transmitter.

RATINGS

NEMA 4: Watertight

EXPLOSION PROOF: Class 1, Division 1, Group C & D
Standard models approved by CSA.

Stroke Length: up to 1.0" (adjustable) 

Thrust: 200 lbs. at minimum step rate for EVA-200

Thrust: 100lbs. at minimum step rate for EVA-100

(See Thrust vs. Speed Chart on page 2)



Shown mounted on Model 9100 valve assembly.

SPECIFICATIONS

Standard Line Voltage: 120/240 VAC, $\pm 10\%$ (Slide switch selectable) 36VA.

Frequency: 50/60 Hz.

Signal Inputs: 4-20 mA, 0-5 VDC, 0-10 VDC.

Incremental Control Input (On/Off control): Two isolated dry contact closures required.

Position Transmitter: 4-20 mA isolated, loop powered with 12-36 VDC external power supply.

Field Wiring Terminations: Plugable terminal block, wire size range 26-14 AWG.

Loss-of-Signal: Fail to Zero, Span or Lock Last (user selectable).

Adjustable Limit Switches: 4 available, open transistor low level logic outputs, adjustable over stroke range. Rating: 40 VDC at 40 mA maximum.

Weight: 16 lbs. (7.3 kg).

Conduit Entry: Two 1/2 NPT.

Temperature Limits: -40° F to 150° F (-40° C to 65° C)

Enclosure: Explosion-proof for Class I, Division 1, Groups C and D. Type 4 (IP65), indoor or outdoor.

Position Accuracy: 1% of full range.

Deadband: Factory preset to 1%. Field adjustable.

Stroke: 1 inch maximum.

Mounting: Horizontal or vertical. (Do not mount upside down in wet or condensing atmospheres.)



Shutoff Pressures

MODEL 9000					EVA-100	EVA-200
VALVE SIZE	TRIM	CV	DIAMETER in.	AREA in ²	SHUTOFF (PSI)	SHUTOFF (PSI)
2"	30.34	25.20	1.5	1.77	42	99
2"	29.33	21.17	1.125	1.0	90	191
2"	28.32	15.14	0.812	0.52	185	379
2"	27.31	7.6.5	0.625	0.31	320	646
1-1/2"	22.26	15.5.13	1.25	1.23	70	151
1-1/2"	21.24	11.10	0.812	0.52	185	379
1-1/2"	19.20,23.24	7.6.5.4	0.625	0.31	320	646
1"	09.18	8.3.7	0.812	0.52	185	379
1"	07.08,16,17	5.3.4.5.2	0.5	0.20	505	720
1"	01.02,03,04,05,06,11,12,13,14,15	1.5.2.1.1.05.02	0.156	0.02	720	720

MODEL 9100					EVA-100	EVA-200
VALVE SIZE	TRIM	CV	DIAMETER in.	AREA in ²	SHUTOFF (PSI)	SHUTOFF (PSI)
2"	54	54	2	3.14	13	45
2"	36.22	36.22	1.75	2.41	25	67
1-1/2"	35	35	1.625	2.07	33	81
1-1/2"	24.15	24.15	1.25	1.23	70	151
1-1/4"	29	29	1.625	2.07	33	81
1-1/4"	20.12	20.12	1.25	1.23	70	151
1"	15	15	1	0.79	118	245
1"	10.6	10.6	0.75	0.44	219	300
1"	3	3	0.5	0.20	300	300
3/4"	12	12	1	0.79	118	245
3/4"	8.6	8.6	0.75	0.44	219	300
3/4"	3	3	0.5	0.20	300	300
1/2"	8.6	8.6	0.75	0.44	219	300
1/2"	3	3	0.5	0.20	300	300

RESEARCH					EVA-1	EVA-100	EVA-200
VALVE SIZE	TRIM	CV	DIAMETER in.	AREA in ²	SHUTOFF (PSI)	SHUTOFF (PSI)	SHUTOFF (PSI)
1"	6	6	0.625	0.3068	124	320	646
1"	5	5	0.625	0.3068	130	320	646
1"	4.5	4.5	0.5	0.1963	199	505	1014
1"-3/4"	4	4	0.4375	0.1503	262	661	1326
1"-3/4"	3.5	3.5	0.4375	0.1503	262	661	1326
1"-3/4",1/2"	A	2.5	0.375	0.1104	359	902	1807
1"-3/4",1/2"	B	2	0.375	0.1104	359	902	1807
1"-3/4",1/2"	C	1.25	0.281	0.0620	642	1610	3222
1"-3/4",1/2"	D	0.8	0.25	0.0491	813	2035	4072
1"-3/4",1/2"	E	0.5	0.25	0.0491	813	2035	4072
1"-3/4",1/2",1/4"	F	0.32	0.156	0.0191	2093	5232*	7500*
1"-3/4",1/2",1/4"	G	0.2	0.156	0.0191	2093	5232*	7500*
1"-3/4",1/2",1/4"	H	0.13	0.156	0.0191	2093	5232*	7500*
1"-3/4",1/2",1/4"	I	0.08	0.156	0.0191	2093	5232*	7500*
1"-3/4",1/2",1/4"	J	0.05	0.156	0.0191	2093	5232*	7500*
1"-3/4",1/2",1/4"	K	0.03	0.086	0.0058	5000	7500*	7500*
1"-3/4",1/2",1/4"	L	0.02	0.086	0.0058	5000	7500*	7500*
1"-3/4",1/2",1/4"	M	0.01	0.086	0.0058	5000	7500*	7500*
1"-3/4",1/2",1/4"	N	0.006	0.086	0.0058	5000	7500*	7500*
1"-3/4",1/2",1/4"	O	0.003	0.086	0.0058	5000	7500*	7500*

Notes

Please consult the catalog for maximum allowable pressure drops for all valves.

Please consult the catalog for pressure/temperature ratings for all valves.

Seat loading was calculated based on a fixed force per orifice circumference normally required to achieve Class IV shut-off.

* Shut-off pressures listed are for the TYPE 1711; 1/4" & 1/2" Type 807 valves are rated at 5,000 psig and 3/4" & 1" Type 752's are rated at 1,500 psi system pressure.

Stroke

Model	Sizes	Stroke (in)
RCV	1/4"	0.438
RCV	1/2", 3/4" & 1"	0.562
9000	ALL	0.750
9100	1/2", 3/4", 1"	0.750
9100	1-1/4", 1-1/2", 2"	1.000

Stroke Speeds

Thrust (lbs.)	Speed (in/s)	0.438	0.562	0.75	1	Valve Stroke (in.)
200	0.13	3.4	4.3	5.8	7.7	Stroke time (sec.)
150	0.19	2.3	3.0	3.9	5.3	Stroke time (sec.)
100	0.25	1.8	2.2	3.0	4.0	Stroke time (sec.)

Wiring Connections

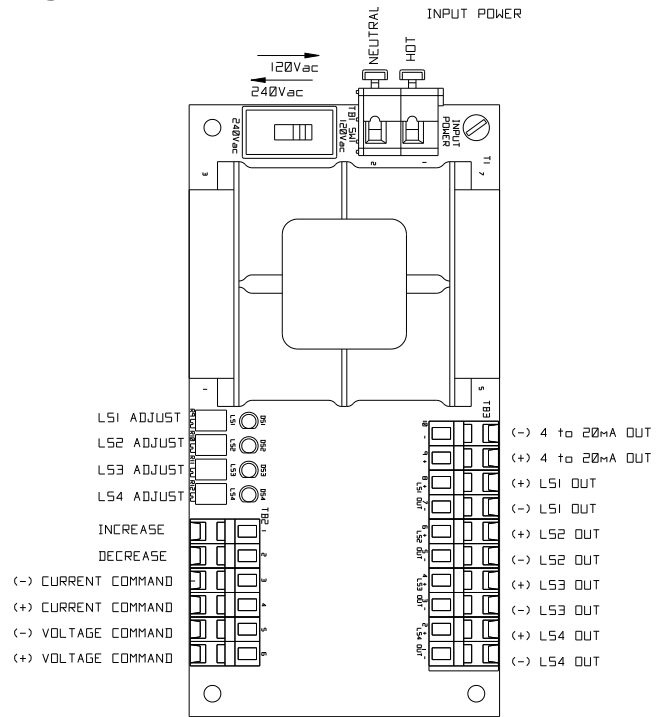

Dimensions

EVA-100

EVA-200

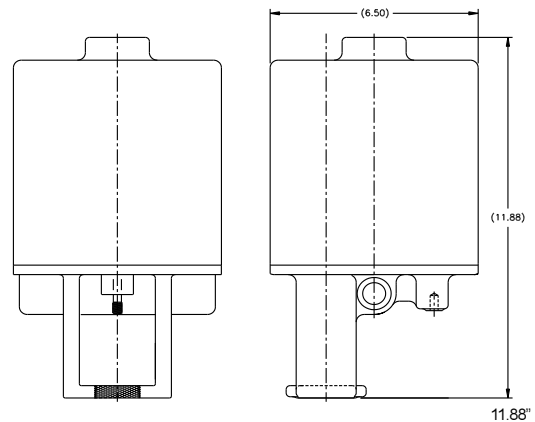

Please see our website at
www.badgermeter.com
 for specific contacts.



Badger Meter, Inc.

P.O. Box 581390, Tulsa, Oklahoma 74158
 (918) 836-8411 / Fax: (918) 832-9962

www.badgermeter.com